

Technical data sheet

Product features



Cooking range drop-in gas 2x burner

Model	SAP Code	00007444
--------------	-----------------	----------

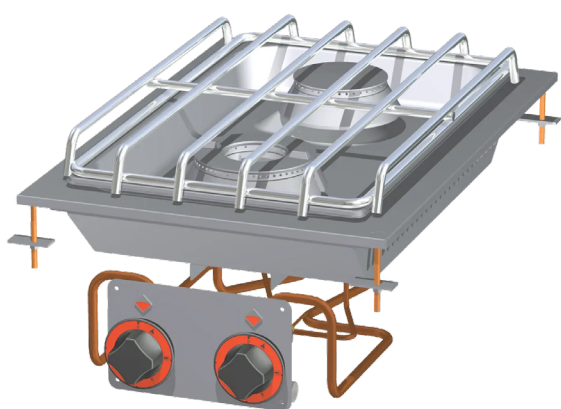

- Device type: Gas unit
- Power consumption of the zone 1 [kW]: 7,5
- Power consumption of the zone 2 [kW]: 5,5
- Ignition: Eternal flame
- Protection of controls: IPX5
- Material: Stainless steel

SAP Code	00007444	Power gas [kW]	13.000
Net Width [mm]	400	Type of gas	Natural gas, propane butane
Net Depth [mm]	600	Number of zones	2
Net Height [mm]	110	Power consumption of the zone 1 [kW]	7,5
Net Weight [kg]	16.00	Power consumption of the zone 2 [kW]	5,5

Technical data sheet

Technical drawing



Cooking range drop-in gas 2x burner

Model

SAP Code

00007444

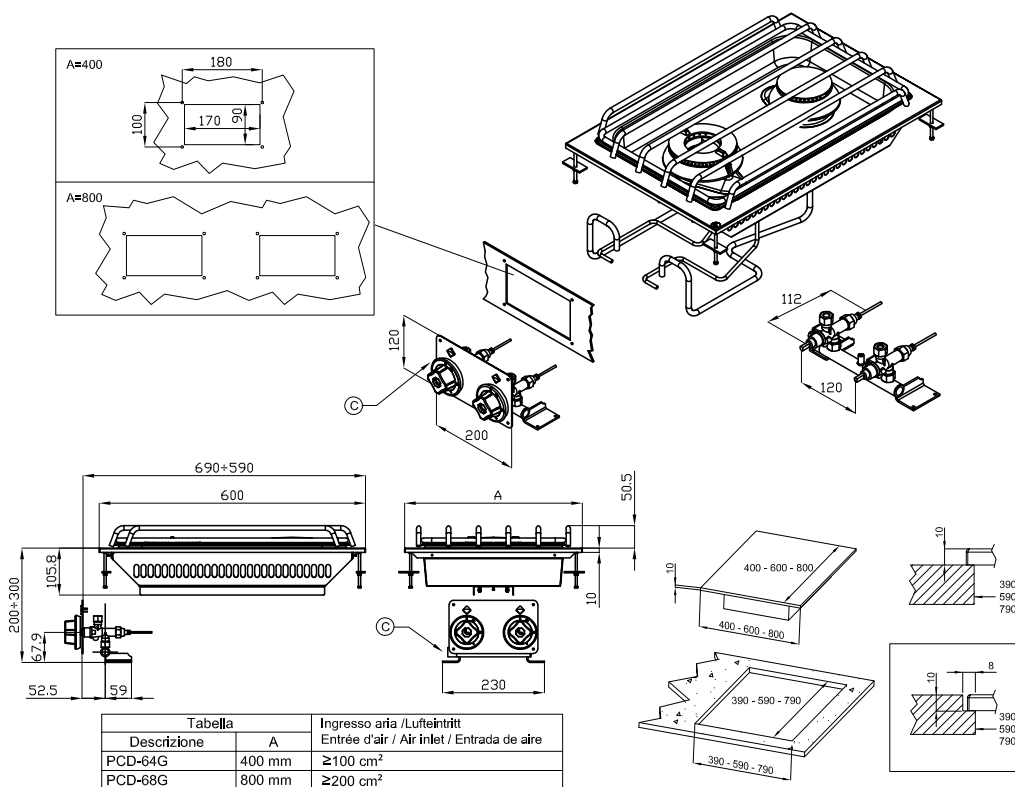

A	Data plate		C	Gas connection	ISO 7-1 1/2" M
---	------------	--	---	----------------	----------------

Technical data sheet

Product benefits



Cooking range drop-in gas 2x burner

Model

SAP Code

00007444

1

Massive construction of burners

high performance and efficiency
cast iron burners removable
long life

- energy saving (perfect combustion)
- time saving for food preparation
- easy maintenance/cleaning

2

Degree of protection of the control elements IPX5

maintenance-free system
resistance to splash water
long life

- savings on service interventions
- easy cleaning and maintenance of equipment

3

All-stainless design

the material does not cut
wear resistance of the material
long life

- savings on service interventions
- easy cleaning and maintenance of equipment

4

Hygienic moldings of the top plate

absence of sharp corners and edges (potential places where dirt could stick)
smooth transitions

- easy quick cleaning

5

Variability

the possibility of attaching to a fixed plate as part of a monoblock
the possibility of creating one module
long life

- cost saving
- space saving
- long service life

6

Safety element - thermocouple

safe service for staff
there is no unnecessary gas leakage
long life

- savings on service interventions
- easier and faster operation

Technical data sheet

Technical parameters



Cooking range drop-in gas 2x burner

Model

SAP Code

00007444

1. SAP Code:

00007444

2. Net Width [mm]:

400

3. Net Depth [mm]:

600

4. Net Height [mm]:

110

5. Net Weight [kg]:

16.00

6. Gross Width [mm]:

470

7. Gross depth [mm]:

700

8. Gross Height [mm]:

530

9. Gross Weight [kg]:

20.00

10. Device type:

Gas unit

11. Construction type of device:

Drop-in

12. Power gas [kW]:

13.000

13. Ignition:

Eternal flame

14. Type of gas:

Natural gas, propane butane

15. Protection of controls:

IPX5

16. Material:

Stainless steel

17. Worktop material:

AISI 304

18. Worktop Thickness [mm]:

2.00

19. Number of zones:

2

20. Power consumption of the zone 1 [kW]:

7,5

21. Power consumption of the zone 2 [kW]:

5,5

22. Number of power control stages:

6

23. Service accessibility:

From the front by removing the front panel and waste fluid containers

24. Safety thermocouple:

Yes

25. Number of burners/hot plates:

2

26. Type of gas cooking zones:

Cast iron burners